

# Adriano

by Romeo Sozzi

Sofas & Armchairs / 2008



# Adriano

by Romeo Sozzi

Sofas & Armchairs / 2008



## Design and features

Adriano was conceived in 2008 by Romeo Sozzi. The imperial inspiration that is at the origin of this modular sofa is the extreme versatility of its modules. Adriano can take different forms, adapting to any spatial composition: from the simple linear version, to the angular version, to the pleasant semi-circular solution.

The design of the landscape sofa is completed by a matching chaise longue-dormeuse.

All versions of Adriano have a wide selection of coverings that allow it to take on different characters and personalities, adapting to the environments they inhabit. The armrest and the wooden table complete the comfort.



# Adriano

by Romeo Sozzi  
Sofas & Armchairs / 2008

## Dimensions

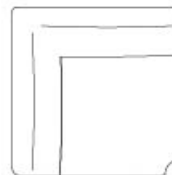
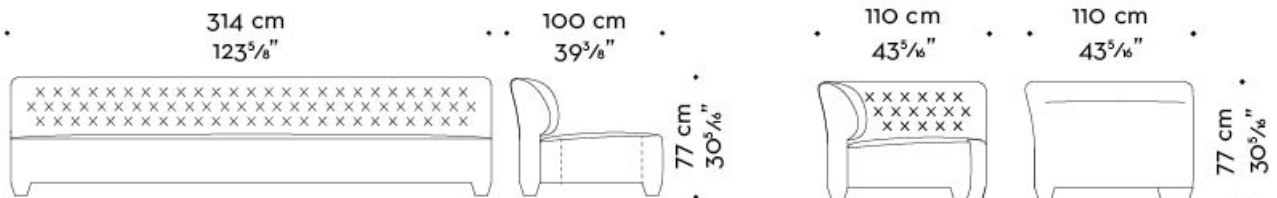
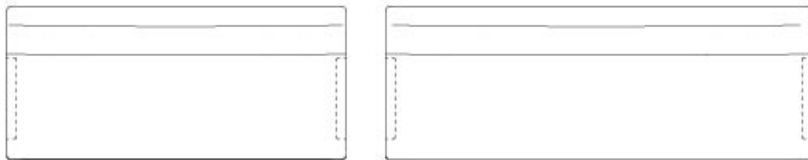
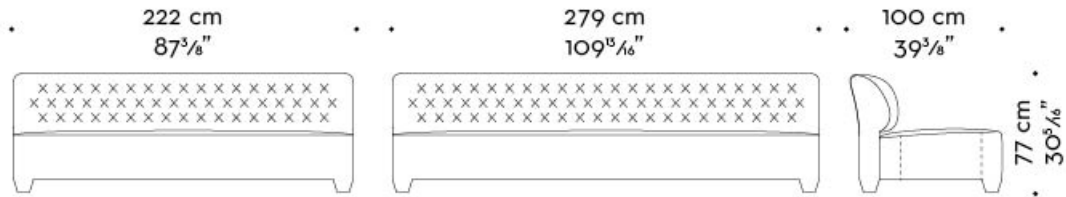
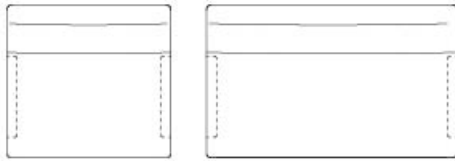
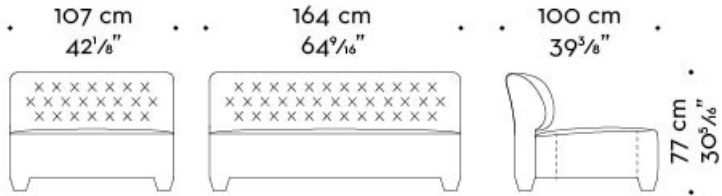

# Adriano

by Romeo Sozzi

Sofas & Armchairs / 2008

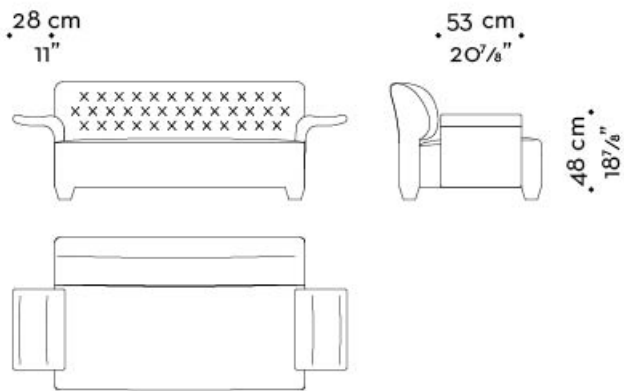
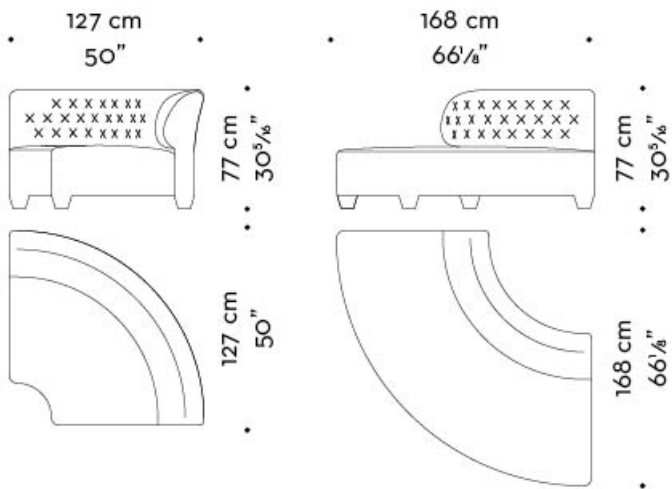

34 cm  
13<sup>3</sup>/<sub>8</sub>"

