

Kyoto atto II

by Romeo Sozzi

Contenitori / The Atelier of Beauty / 2019



Kyoto atto II

by Romeo Sozzi

Contenitori / The Atelier of Beauty / 2019



Impressioni d'oriente

Kyoto atto II è una madia che si ispira alla cultura giapponese. Rivisitazione di una madia già presente in passato a collezione con lo stesso nome, Kyoto atto II, conserva le linee essenziali del design originale. A renderla estremamente contemporanea è invece la scelta dei materiali, con interni ed esterni in semilucido.

Kyoto atto II è disponibile con: cassettera interna, la finitura semilucido satinata a mano solo per esterno, ante in tessuto e illuminazione interna a LED.



Kyoto atto II

by Romeo Sozzi

Contenitori / The Atelier of Beauty / 2019

Dimensioni

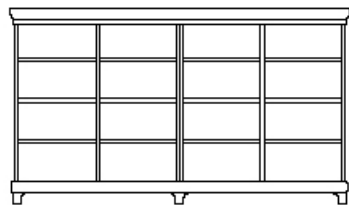
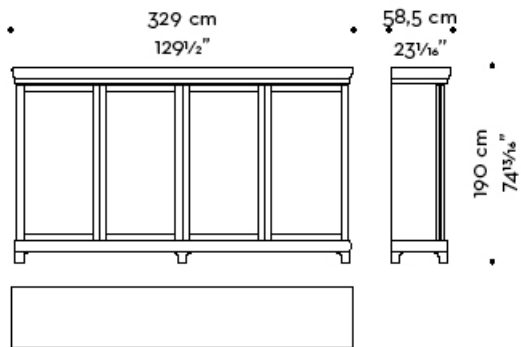

vista interno
inside view

